

Butterfly Valves Made of Ductile Cast Iron DN 100 - DN 1200

for water and gas supply pipelines

Düker Butterfly Valves – Safe, Flow-optimised and Resistant

In Germany alone, many thousands of kilometres of pipelines ensure that water is at our disposal everywhere and anytime.

The pipeline materials used for this purpose have to fulfil high demands:

- resist to any ground movements
- work reliably for years
- remain impeccably hygienic
- transport our drinking water safely and loss-free

It all Depends on the Material

Cast iron as a natural material is the basis of all Düker valves. Due to its excellent material characteristics, it fulfils these requirements completely:

- longevity
- water tightness
- good corrosion resistance
- economy
- and last but not least 100% recyclability

Permanent Protection all Around

In order to ensure an even better and permanent protection against corrosion and incrustation, our butterfly valves are enamelled as a standard coating. Up to DN 600, the butterfly valves are enamelled inside and outside; above DN 600 they are enamelled inside.

Bacteria cannot attach themselves to the smooth enamel surface. Therefore, the adhesion of biofilms is actively avoided, which guarantees absolutely safe drinking water supply – even in case of varying temperatures.



Düker Butterfly Valves

Our butterfly valves are used both for drinking water and raw water and for all gas types (including pressurized air). On request, the butterfly valve may also be used for different media.

Nominal pressures are PN 10, PN 16 and PN 25, with the maximum operating and differential pressure being equal to the nominal pressure. The flanges are in accordance with the DIN standards 28604, 28605 or 28606. Flanges as per ASA and BSI are available on request. The maximum operating temperature for water is 60 °C. The indications for gas follow G 260 / I.

Execution of the Disc

The Düker butterfly valves have a flow-optimised, double-eccentric disc. The profile sealing can easily be adjusted and changed.

The shaft bearings run in maintenance-free bush bearings. The shafts are sealed through O-rings inside and outside. On the gear box cover, there is an

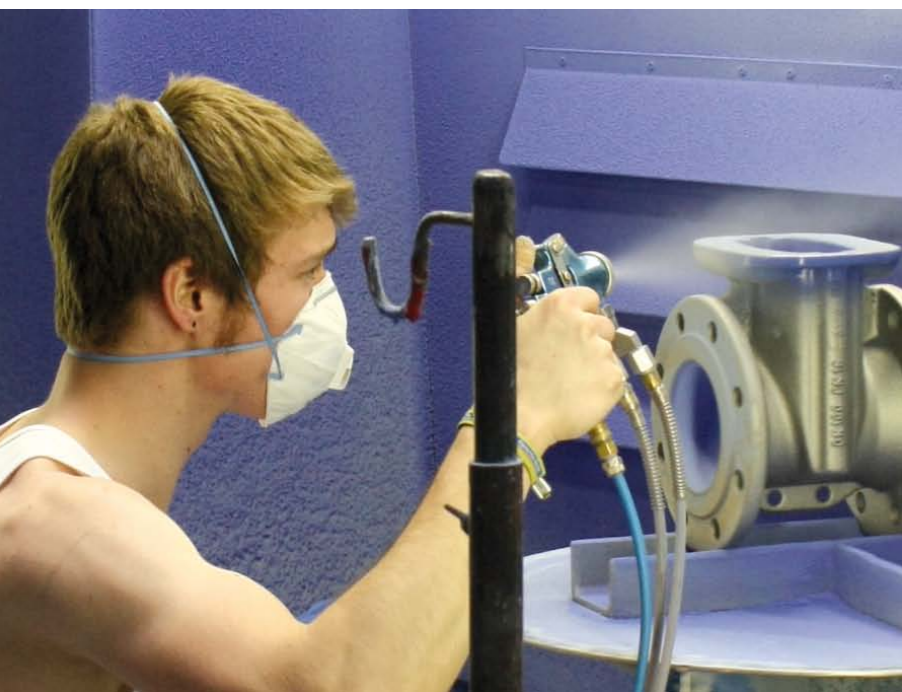

etec enamel – the special all around surface protection for Düker butterfly valves

etec enamel – a compound material which forms an inseparable, chemical bond with the base material ductile cast iron, convinces due to:

- corrosion protection inside and outside up to soil class III
- high resistance against mechanical stress (friction, impact, pressure, thrust)
- resistance to ageing
- no diffusion of water through the coating,

Düker[®]
etec

- which might cause blisters between the base material and the coating
- safety against penetration under the coating even in case of local damages to the surface
- resistance to climate and medium (UV radiation, humidity, temperature, organic solvents)



open/closed indication. The end stop "closed" of the gear can be adjusted. The driving can be done with handwheel, an adapter as per GW 366, with an electric actuator, and with hydraulic or pneumatic actuators.

Butterfly Valves Type 4510 and 451 – the essential advantages

Flow-Optimised Disc

The Düker butterfly valves have a flow-optimised disc with double-offset journal. This bearing causes a slight rotation at the moment of opening and closing the valve, which is in addition superimposed by

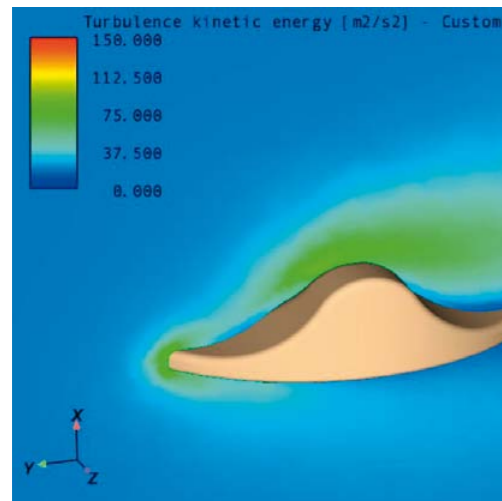

a translatory motion. Therefore the disc separates from the housing at only a slight degree of opening, which relieves the sealing safely.

Resistance values (zeta values) in open position

DN	type	zeta-value
100	4510	0.80
150	4510	0.75
200	4510	0.70
250	4510	0.67
300	4510	0.65
350	4510	0.62
400	4510	0.60
500	4510	0.55
600	4510	0.50
700	451	0.47
800	451	0.45
900	451	0.42
1000	451	0.40
1200	451	0.35

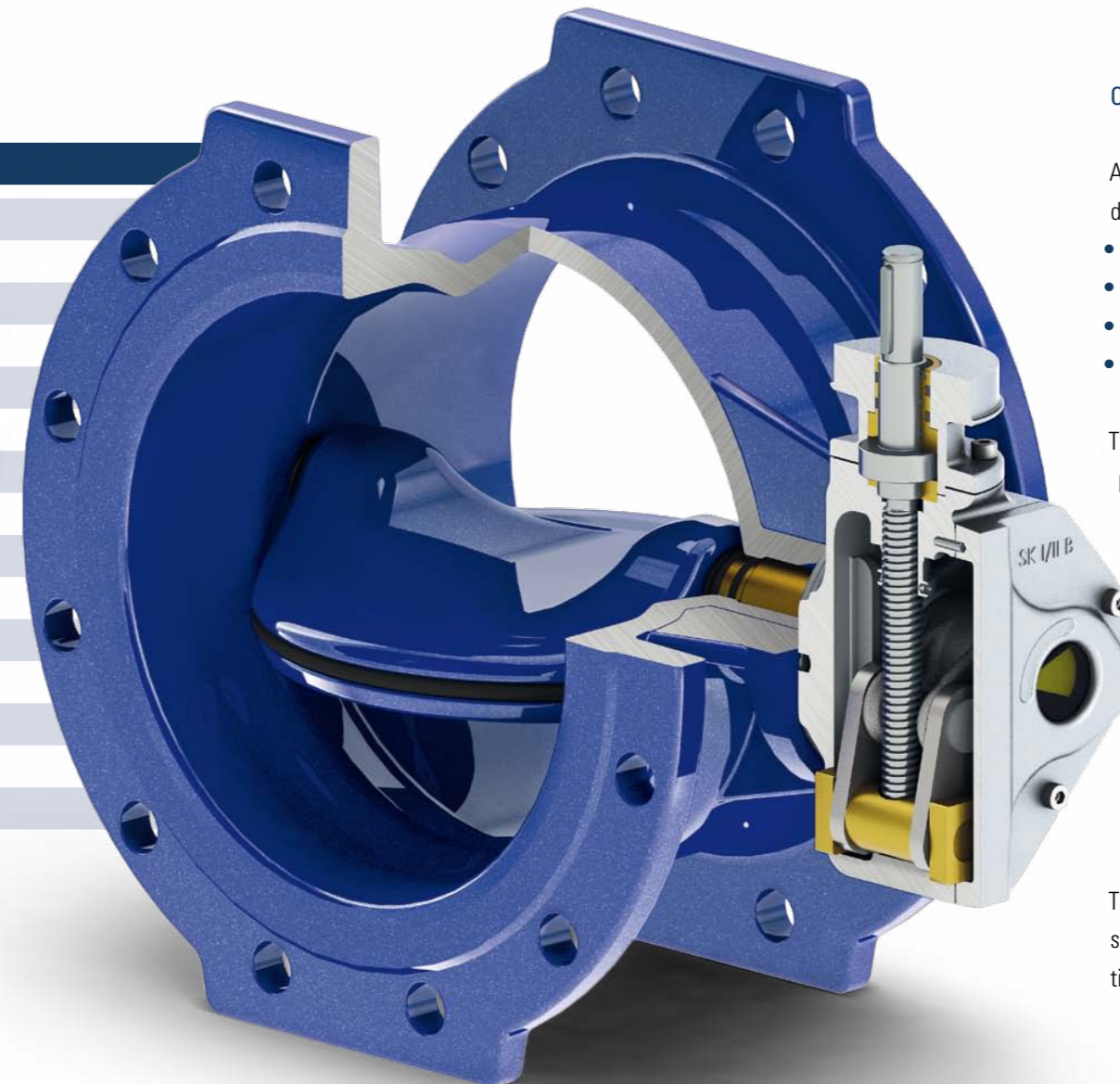

Optimised Gear Box

As an option, our gear boxes have the following driving modes:

- handwheel with ball knob
- electric actuator
- stem extension with wheel type indicator
- stem extension without wheel type indicator

The Düker gears with slidercrank mechanism have proven themselves for years and are adapted optimally to the Düker butterfly valve.

At a uniform initial revolution speed, the closing speed decreases, so the gear closes softly. This mechanism reduces or eliminates pressure peaks.

The gear box is chambered watertight and corresponds to the degree of protection IP 68.

The mechanical position indication (open/closed) is situated on the gear box below a transparent plastic cover and is linked directly to the shaft.

Wear-Resistant Bearing and Driving Shaft

The bearing sleeves made of bronze are highly wear-resistant and show an excellent behaviour regarding surface pressure and friction coefficients.

The driving shaft and bearing journal made of stainless steel are chambered medium-free thanks to a newly developed sealing configuration between the bearing lug of the disc and the bearing sleeve.

The connection between the disc and the shaft is through a square plug connection. In combination with the bronze material of the bearing sleeve, this square plug connection ensures a safe and easy operability.

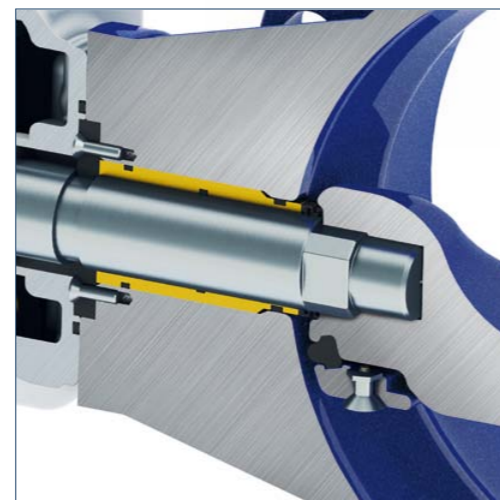

Easily Replaceable Sealing Ring

This disc sealing, a profile ring, is a resilient-sealing loop, which runs alongside the shaft axle and seals directly on the smooth enamel. It is fixed to the disc with a retaining ring.

The profile ring with one-piece retaining ring ensures a uniform and controlled pre-tension, which allows the sealing to be exchanged without problems in the "open" position.

Special Versions

Special versions are possible on request - for example: butterfly valves with three-point locking device for prevention of accidents during maintenance or revision work. Please consult us.

Butterfly Valves Type 4510 and 451 – Materials and Versions

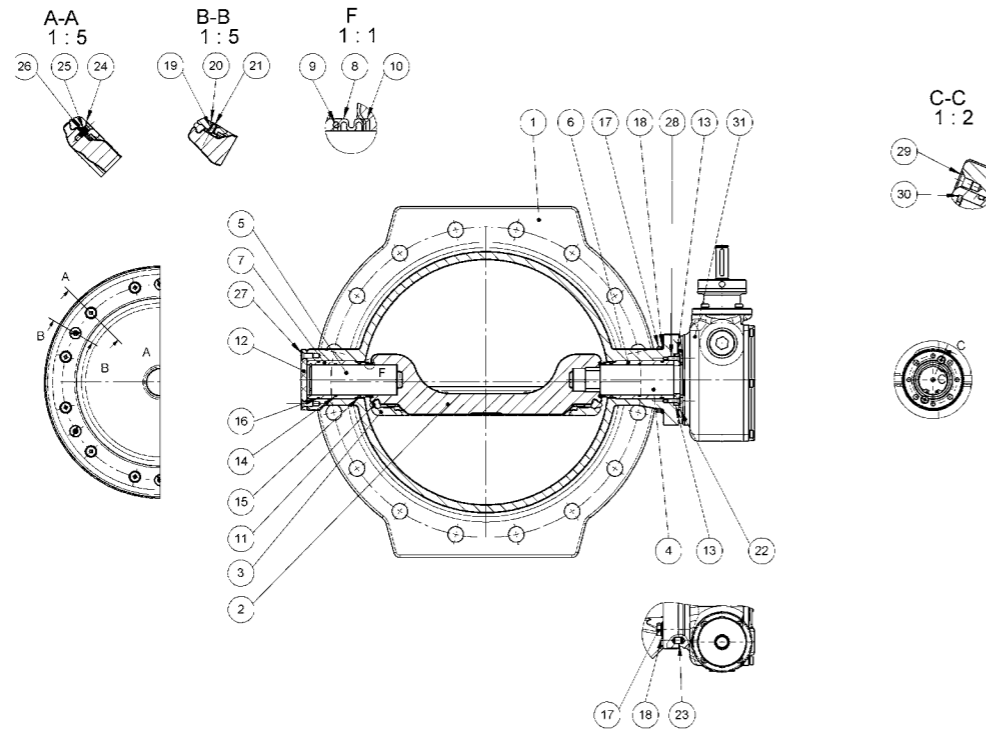

Details and Materials

item	description	material	item	description	material
1	Body	EN-GJS-400-15	18	washer	A2
2	Disc	EN-GJS-400-15	19	threaded sleeve lower part	X20Cr13
3	Retaining ring	EN-GJS-500-7	20	threaded sleeve upper part	X20Cr13
4	Shaft	X20Cr13	21	headless screw	A2
5	Bearing journal	X20Cr13	22	O-ring	NBR
6	Bearing sleeve A	GZ-CuSn7SnPb	23	cylinder pin	Cq22, Cq35
7	Bearing sleeve B	GZ-CuSn7SnPb	24	washer bush	POM
8	Sealing ring	PE 100	25	countersunk screw	A2
9	O-ring	NBR	26	O-ring	NBR
10	Sealing	EPDM	27	countersunk screw	A2
11	Profile sealing	EPDM	28	countersunk screw	A2
12	Blind pin	PA6GF30	29	countersunk screw	A2
13	Connection ring module	PA6GF30	30	safety ring	Ck 75
14	O-ring	NBR	31	gearbox SK I/II B	EN-GJS-500-7
15	O-ring	NBR			
16	O-ring	NBR			
17	Hexagonal screw	A2		Other materials on request	

Versions

type	DN	PN	flanged	long with bypass	long without bypass	Novo sockets	etec enamel inside and outside	inside enamel, outside 2-components epoxy paint
4510	100	10-25	•				•	
4510	125	10-25	•				•	
4510	150	10-25	•			•	•	
4510	200	10-25	•			•	•	
4510	250	10-25	•			•	•	
4510	300	10	•	•	•	•	•	
4510	300	16	•	•	•	•	•	
4510	300	25	•			•	•	
4510	350	10-25	•				•	
4510	400	10	•	•	•	•	•	
4510	400	16	•	•	•	•	•	
4510	400	25	•			•	•	
4510	500	10	•	•	•	•	•	
4510	500	16	•	•	•	•	•	
4510	500	25	•			•	•	
4510	600	10	•	•	•		•	
4510	600	16	•	•	•		•	
4510	600	25	•				•	
451	700	10	•	•	•			•
451	700	16	•	•	•			•
451	700	25	•					•
451	800	10-16	•	•	•			•
451	900	10-16	•	•	•			•
451	1000	10-16	•	•	•			•
451	1200	10-16	•					•

Butterfly Valves with our without Handwheel

Basic version

model	nominal dimension DN in mm	nominal pressure PN in bar	length L in mm	flange ø D in mm	foot dimension B in mm	height h1 in mm	dimension t1 in mm	dimension t2 in mm	dimension x1 in mm	gear SK
4510	100	10/16	190	220	120	116	110	258	65	I B
4510	100	25	190	235	120	121	110	258	65	I B
4510	125	10/16	200	250	130	131	122	270	65	I B
4510	125	25	200	270	130	141	122	270	65	I B
4510	150	10/16	210	285	150	149	138	286	65	I B
4510	150	25	210	300	150	157	138	286	65	I B
4510	200	10	230	340	160	177	175	311	65	II B
4510	200	16	230	340	160	177	175	311	65	II B
4510	200	25	230	360	160	187	175	311	65	II B
4510	250	10	250	400	180	208	212	348	65	II B
4510	250	16	250	400	180	208	212	348	65	II B
4510	250	25	250	425	180	220	212	348	65	II B
4510	300	10	270	455	200	233	221	371	65	II B
4510	300	16	270	455	200	233	221	371	65	II B
4510	300	25	270	485	200	248	221	371	65	II B
4510	350	10	290	505	225	259	287	426	65	II B
4510	350	16	290	520	225	269	287	426	65	II B
4510	350	25	290	555	225	287	287	426	65	II B
4510	400	10	310	565	300	294	307	446	65	II B
4510	400	16	310	580	300	294	307	474	100	III
4510	400	25	310	620	300	319	307	474	100	III
4510	500	10	350	670	350	350	377	524	100	III
4510	500	16	350	715	350	372	377	524	100	III
4510	600	10	390	780	320	401	442	614	100	III
4510	600	16	390	840	330	431	442	673	160	IV
4510	600	25	390	845	400	431	442	693	160	IV
451	700	10	430	895	400	450	549	665	150	IV
451	700	16	430	910	400	460	549	665	150	IV GZ
451	700	25	430	960	450	485	549	665	150	IV GZ
451	800	10	470	1015	450	510	594	710	150	IV GZ
451	800	16	470	1025	450	515	594	710	150	IV GZ
451	900	10	510	1115	550	560	634	750	150	IV GZ
451	900	16	510	1125	550	568	634	740	200	GS 200 GZ
451	1000	10	550	1230	600	620	699	815	150	IV GZ
451	1000	16	550	1255	600	630	699	805	255	GS 250 GZ
451	1200	10	630	1455	700	730	828	903	255	GS 250 GZ
451	1200	16	630	1485	700	750	828	903	255	GS 250 GZ

without handwheel

height h2 in mm	stem ø d in mm	weight ca. kg
223	20	32
223	20	33
223	20	37
223	20	38
223	20	43
223	20	43
223	20	55
223	20	55
223	20	60
223	20	74
223	20	73
223	20	80
223	20	91
223	20	96
223	20	104
223	20	115
223	20	122
223	20	144
223	20	148
278	20	190
278	20	214
278	20	244
278	20	274
278	20	346
403	30	500
403	30	531
403	30	645
403 / 465	30 / 20	663
403 / 465	30 / 20	748
403 / 465	30 / 20	900
403 / 465	30 / 20	915
403 / 465	30 / 20	1198
465	20	1261
403 / 465	30 / 20	1488
568	20	1655
568	20	2065
568	20	2135

with handwheel

height h2 in mm	handwheel ø d1 in mm	weight ca. kg
325	200	33
325	200	34
325	250	38
325	250	39
325	250	44
325	250	44
325	250	56
325	250	56
325	250	61
325	250	75
325	250	74
325	250	81
325	250	92
325	250	97
325	250	105
325	250	116
325	250	123
325	250	145
325	250	149
315	315	192
315	315	216
315	315	246
315	315	276
315	315	348
500	500	506
500	500	537
570	500	650
745	400	665
745	400	750
745	400	902
745	400	917
745	400	1200
675	400	1263
745	400	1490
715	640	1660
715	640	2070
715	640	2140

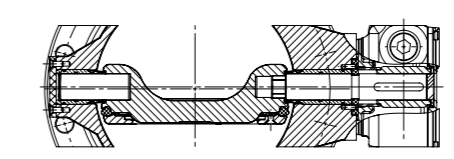
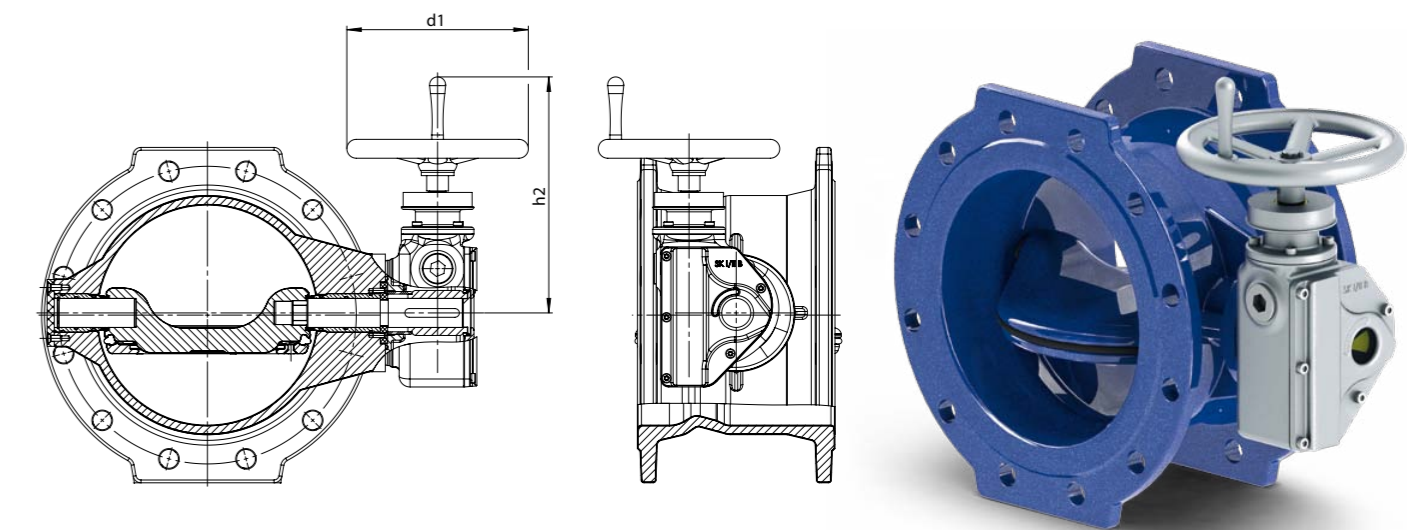
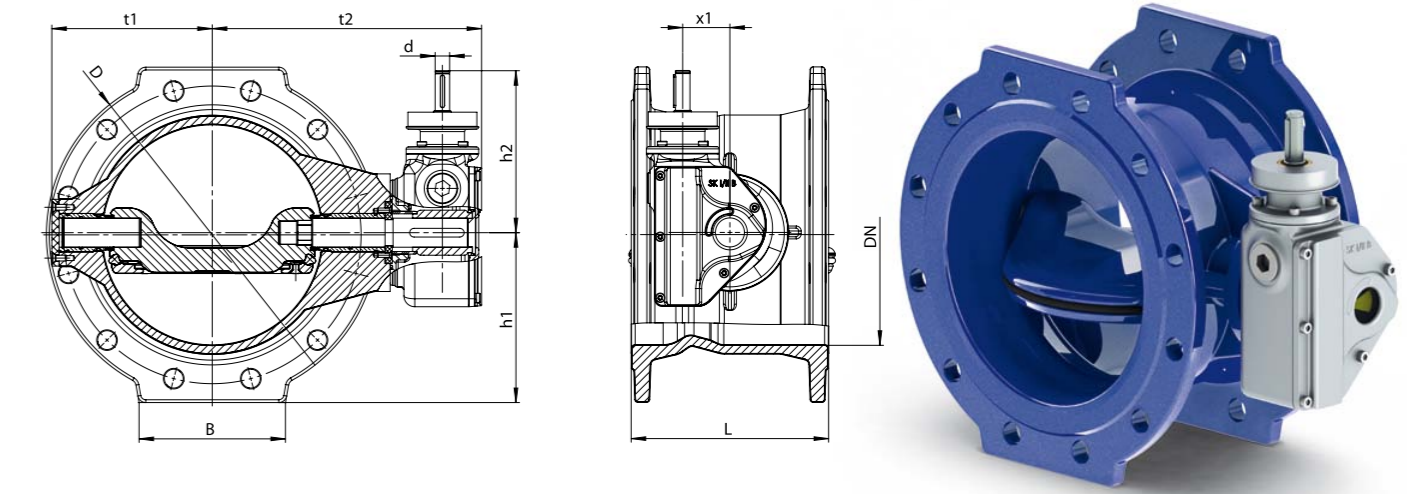

disc type 4510

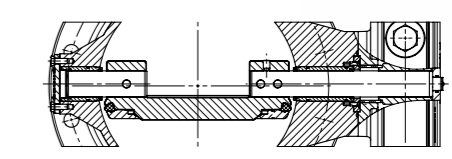

disc type 451

Please note: for the underground installation we supply butterfly valves with height-adjustable telescope stem extension sets in various lengths. In the nominal dimensions DN 700 up to DN 1200, there is no open/closed indicator included in this case.

DN 800 up to DN 1200: PN 25 is available, however the admissible operating pressure is only 20 bar.

Butterfly Valves with Electric Actuator

model	nominal dimension DN in mm	nominal pressure PN in bar	flange ø D in mm	foot dimension B in mm	height h1 in mm	height h2 in mm	dimension t1 in mm	dimension t2 in mm	dimension k in mm	gear SK	actuator
4510	100	10/16	220	120	116	445	110	404	557	I B	AUMA SA 07.6
4510	100	25	235	120	121	445	110	404	557	I B	AUMA SA 07.6
4510	125	10/16	250	130	131	445	122	416	557	I B	AUMA SA 07.6
4510	125	25	270	130	141	445	122	416	557	I B	AUMA SA 07.6
4510	150	10/16	285	150	149	445	138	432	557	I B	AUMA SA 07.6
4510	150	25	300	150	157	445	138	432	557	I B	AUMA SA 07.6
4510	200	10	340	160	177	445	175	457	557	II B	AUMA SA 07.6
4510	200	16	340	160	177	445	175	457	557	II B	AUMA SA 07.6
4510	200	25	360	160	187	445	175	457	557	II B	AUMA SA 07.6
4510	250	10	400	180	208	445	212	494	557	II B	AUMA SA 07.6
4510	250	16	400	180	208	445	212	494	557	II B	AUMA SA 07.6
4510	250	25	425	180	220	445	212	494	557	II B	AUMA SA 07.6
4510	300	10	455	200	233	445	221	517	557	II B	AUMA SA 07.6
4510	300	16	455	200	233	445	221	517	557	II B	AUMA SA 07.6
4510	300	25	485	200	248	445	221	517	557	II B	AUMA SA 07.6
4510	350	10	505	225	259	445	287	572	557	II B	AUMA SA 07.6
4510	350	16	520	225	269	445	287	572	557	II B	AUMA SA 07.6
4510	350	25	555	225	287	445	287	572	557	II B	AUMA SA 07.6
4510	400	10	565	300	294	445	307	592	557	II B	AUMA SA 07.6
4510	400	16	580	300	294	501	307	574	580	III	AUMA SA 10.2
4510	400	25	620	300	319	501	307	574	580	III	AUMA SA 10.2
4510	500	10	670	350	350	501	377	624	580	III	AUMA SA 10.2
4510	500	16	715	350	372	501	377	624	580	III	AUMA SA 10.2
4510	600	10	780	320	401	501	442	714	580	III	AUMA SA 10.2
4510	600	16	840	330	431	626	442	773	580	IV	AUMA SA 10.2
4510	600	25	845	400	431	626	442	793	580	IV	AUMA SA 10.2
451	700	10	895	400	450	590	549	490	490	IV w. red. gear	AUMA SA 10.2
451	700	16	910	400	460	830	549	490	490	IV w. red. gear	AUMA SA 10.2
451	700	25	960	450	485	830	549	490	490	IV w. red. gear	AUMA SA 10.2
451	800	10	1015	450	510	828	594	590	590	IV w. red. gear	AUMA SA 10.2
451	800	16	1025	450	515	830	594	600	600	IV w. red. gear	AUMA SA 10.2
451	900	10	1115	550	565	830	634	530	530	IV w. red. gear	AUMA SA 10.2
451	900	16	1125	550	565	733	699	545	545	GS 200 red. gear	AUMA SA 10.2
451	1000	10	1230	600	620	830	699	550	550	IV w. red. gear	AUMA SA 10.2
451	1000	16	1255	600	630	817	828	640	640	GS 250 red. gear	AUMA SA 10.2
451	1200	10	1455	700	730	817	830	685	685	GS 250 red. gear	AUMA SA 10.2
451	1200	16	1485	700	750	817	830	685	685	GS 250 red. gear	AUMA SA 10.2

Butterfly Valve with Electric Actuator AUMA

The standard version of the Auma actuator includes:

- limit switch for the end positions open/closed
- continuously adjustable torque switch for left and right rotation
- indicator flasher for the function indication (1 impulse per rotation)
- three thermo switches
- handwheel for emergency operation
- heating 220V/230V (220V for DN 100/PN10 up to DN 600/PN25; 230V for DN 700/PN up to DN 1200/PN16)
- central plug for motor and control system, degree of protection of the actuator IP 67 as per DIN 40050/IEC 529
- three-phase motor 400 V 50 Hz.

Optional extras: mechanical position indication, potentiometer (please indicate Ohm value), intermediate position switch and tandem switch. On request, further additional devices are available.

On request, different actuator brands are available.

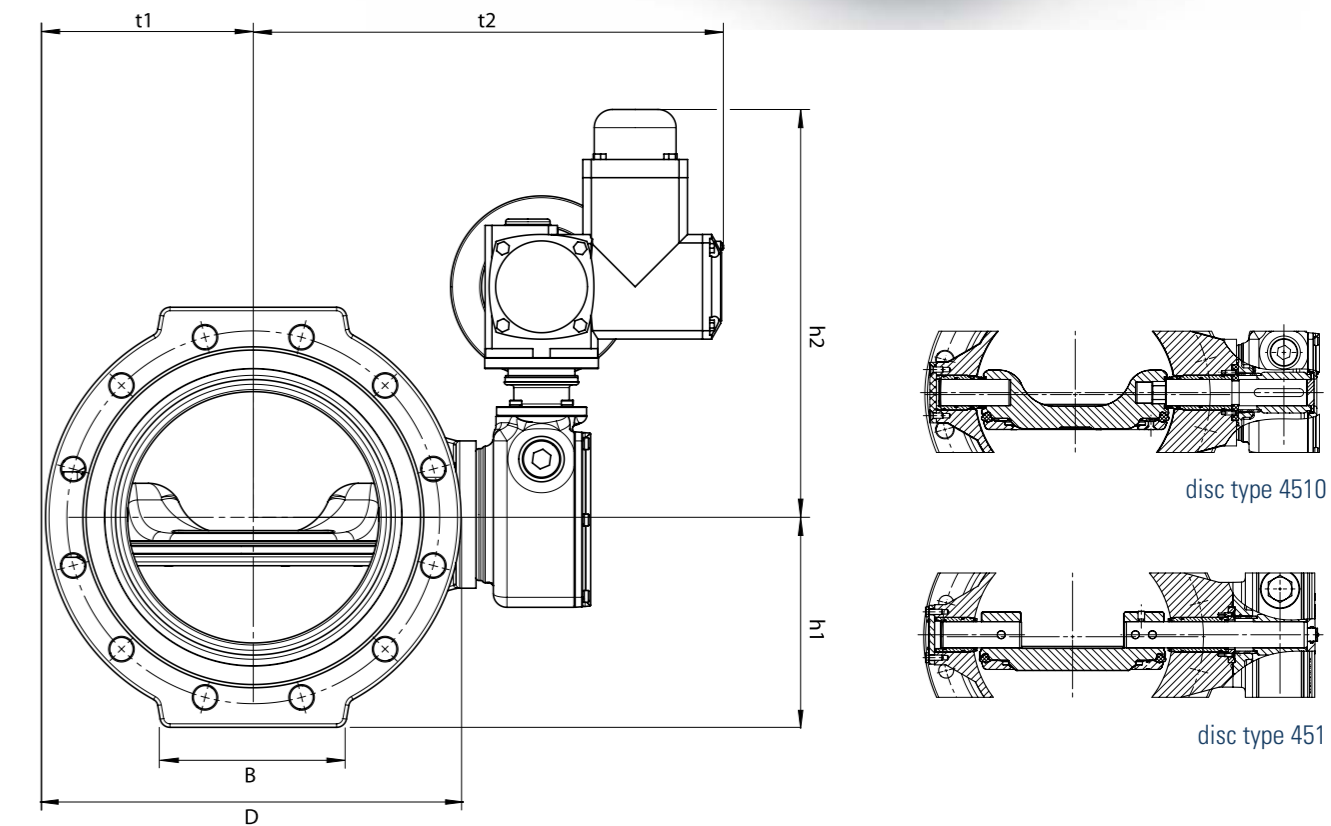
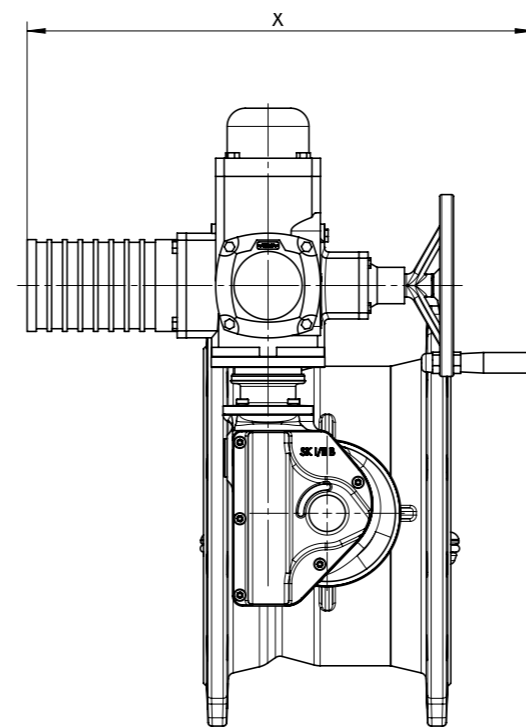

Please note: DN 800 up to DN 1200: PN 25 is available, however the admissible operating pressure is only 20 bar.

Please indicate with your inquiry or order:

- motor tension in V
- frequency in Hz
- control tension in Vss
- closing time in minutes
- degree of protection

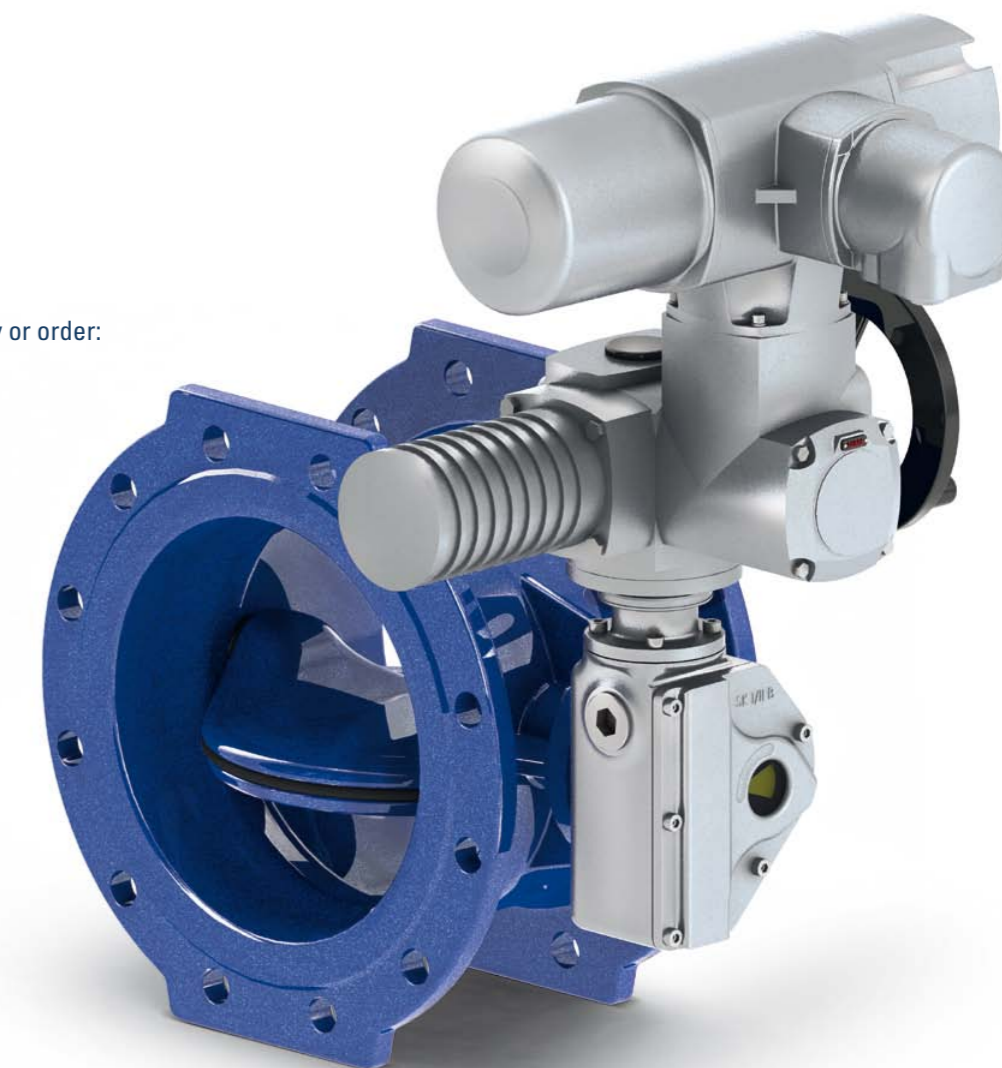

Butterfly Valves Long Body, with or without Bypass

Use of Butterfly Valves with Bypass

The butterfly valves with bypass serve for the otherwise difficult air release from pipelines with several high points.

The bypass normally contains its own shut-off valve and is dimensioned to one tenth of the main nominal dimension. The length of the standard butterfly valve is increased in order to install the bypass, to the length as per EN 558 series 15 (F15).

The bypass has two main advantages:

- the supply pipelines can be filled slowly for efficient air release
- the valves, which are under pressure from one side, can be operated without requiring elevated force. The required pressure equalisation is carried out via the bypass. Therefore the pipeline is protected from pressure peaks.

Operation of the Butterfly Valve with Bypass

Normally, when opening the valve, first the bypass valve and then the main valve are opened. While the water flows, both valves remain open.

The process is applied vice versa when closing the valves: First the main valve, then the bypass valve is closed.

Air vent problems and pressure peaks do not pose a problem in this procedure.

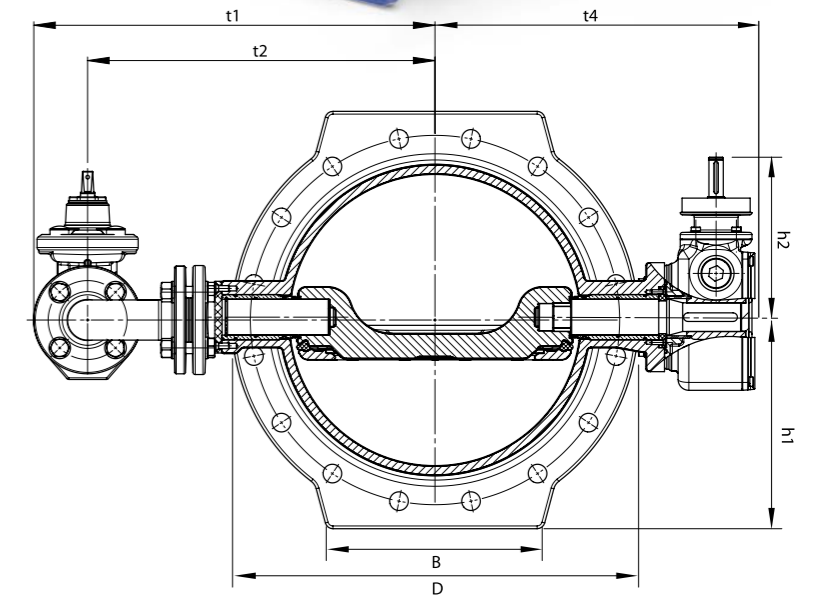
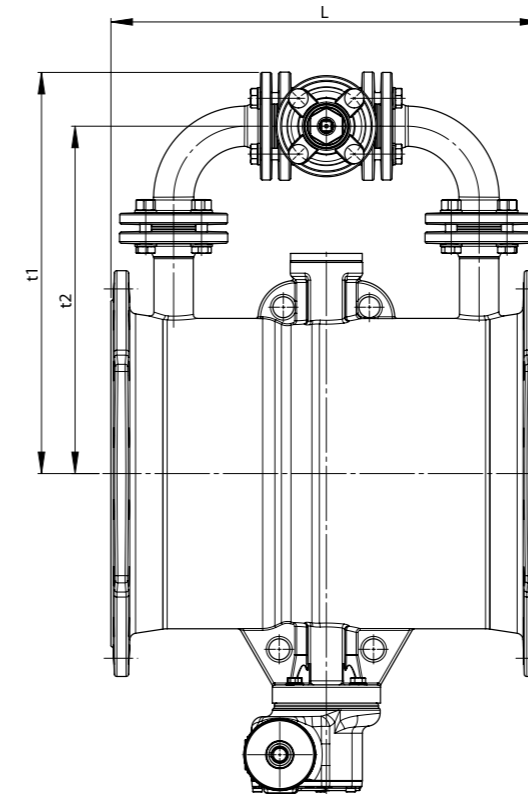
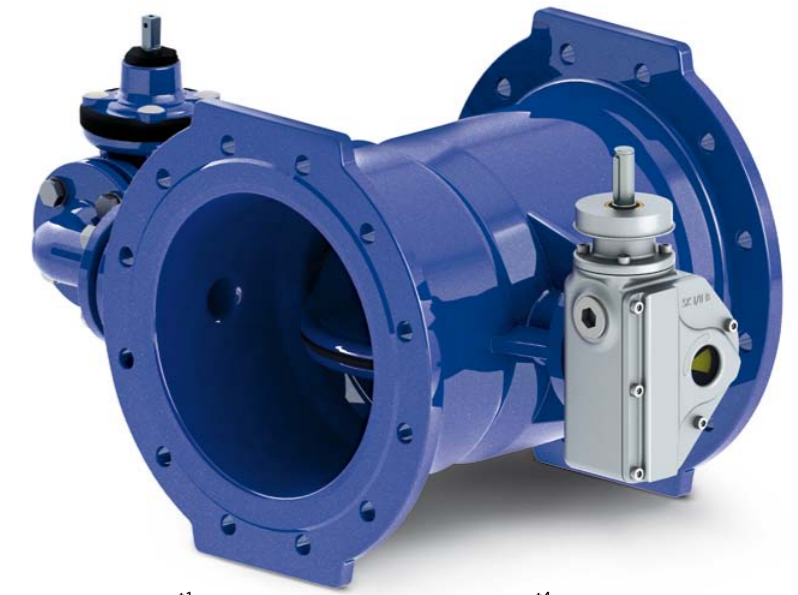

Basic long version

model	nominal dimension DN in mm	nominal pressure PN in bar	length L in mm	flange ø D in mm	foot dimension B in mm	height h1 in mm	height h2 in mm	dimension t4 in mm	gear SK
4510	300	10	500	455	200	233	223	317	II B
4510	300	16	500	455	200	233	223	317	II B
4510	400	10	600	565	300	294	223	392	II B
4510	400	16	600	580	300	294	223	420	III
4510	500	10	700	670	350	350	278	470	III / GS 125 GZ
4510	500	16	700	715	350	372	278	470	III
4510	600	10	800	780	320	401	278	560	III / GS 160 GZ
4510	600	16	800	840	330	431	278	619	IV
451	700	10	900	895	400	450	403	665	IV
451	700	16	900	910	400	460	403	665	IV
451	800	10	1000	1015	450	510	403	710	IV GZ
451	800	16	1000	1025	450	515	403	710	IV GZ
451	1000	10	1200	1230	600	620	403	805	IV GZ
451	1000	16	1200	1255	600	630	568	805	IV GZ

* long version without bypass on request

with bypass*

dimension t1 in mm	dimension t2 in mm	DN of the bypass in mm	weight in kg
480	405	40	150
480	405	40	150
559	485	40	218
559	485	40	259
568	505	50	333
568	505	50	366
637	554	50	462
637	554	50	635
745	650	80	680
745	650	80	680
840	730	80	1085
840	730	80	1085
965	845	100	2060
965	845	100	2060

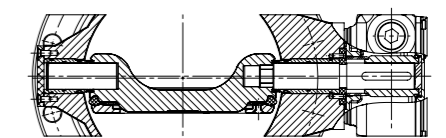

disc type 4510

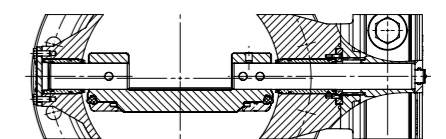

disc type 451

Butterfly Valves with Novo Sockets

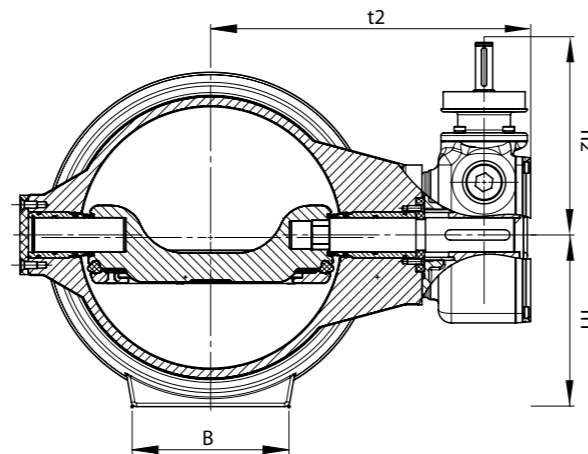
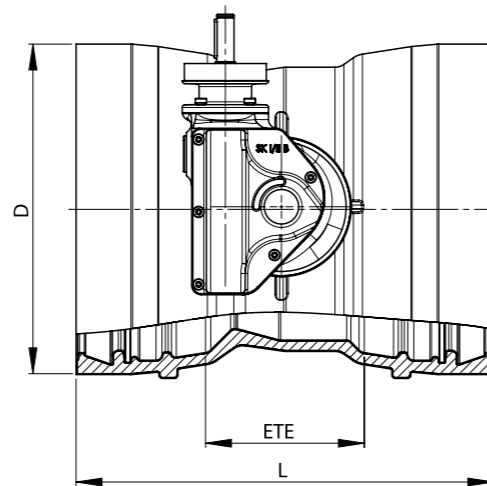

type	nominal dimension DN in mm	nominal pressure PN in bar	socket ø D in mm	length ETE in mm	length L in mm	foot dimension B in mm	height h1 in mm	height h2 in mm	dimension t1 in mm	dimension t2 in mm	gear SK
4510	150	10 - 25	216	106	360	150	147	300	177	231	I B
4510	200	10 - 25	271	111	383	160	175	300	202	256	II B
4510	250	10 - 25	324	116	398	180	205	300	248	300	II B
4510	300	10 - 25	381	121	413	200	230	380	263	317	II B
4510	400	10 - 25	489	172	472	250	285	380	328	382	III
4510	500	10 - 25	598	205	527	300	340	400	370	465	III

Thrust-resisting connections of ductile iron butterfly valves with pipes made of PEHD plastic are possible in the nominal dimensions DN 150 up to DN 200.



Quality on the Highest Level

Düker valves are used worldwide and are subject to elevated requirements in the drinking water sector. Therefore each valve is tested with extreme care before it leaves the factory.

It goes without saying that the requirements of the DVGW worksheet W 270 "Reproduction of microorganisms on materials for the drinking water sector – tests and evaluation" are observed.



Quality Management

We apply high requirements on the quality of our products. Therefore, as early as in 1993, we introduced a modern quality management system as per EN ISO 9001, which is certified by TÜV CERT. Furthermore our products are tested and approved according to numerous other product or market-specific standards and regulations.

For some products, in the framework of quality protection associations, we voluntarily observe criteria that surpass the standard requirements by far.

Regular and random tests, internal and external audits, but also our staff's motivation ensure that the QM system, as an integral part of the overall organisation, is permanently developed. This means, also for the future, that we supply products which convince through their longevity and are up to the latest state of the art.

FITTINGS AND VALVES

DRAINAGE TECHNOLOGY

ENGINEERING

GLASS LINING TECHNOLOGIES

JOBGING FOUNDRY

Düker GmbH & Co. KGaA

Hauptstraße 39-41
63846 Laufach
Germany

Tel. +49 6093 87-560

Fax +49 6093 87-246

E-Mail: sales.fittings-valves@dueker.de

Internet: www.dueker.de